

EPF20R Platform Series

Imperial
Data

Load Range: 3.5 to 45 lbs

all dimensions in
inches

Features & Benefits

- Easy to Install
- Provides Uniform Stress Distribution
- Loading in the Axial Direction
- Minimum Installation Space Required

Material Information

- Elastomer: Natural Rubber
- Metals: Low Carbon Steel
Rust Preventative Coating
- Temperature Range: -40°F to 180°F

Typical Applications

- Air Conditioners
- Appliances
- Business Machines
- Electronics
- Small Generators

Mount Installation

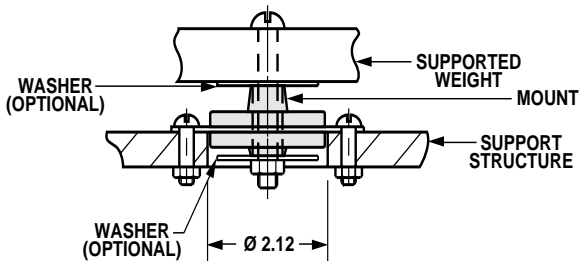

Mount Dimensions

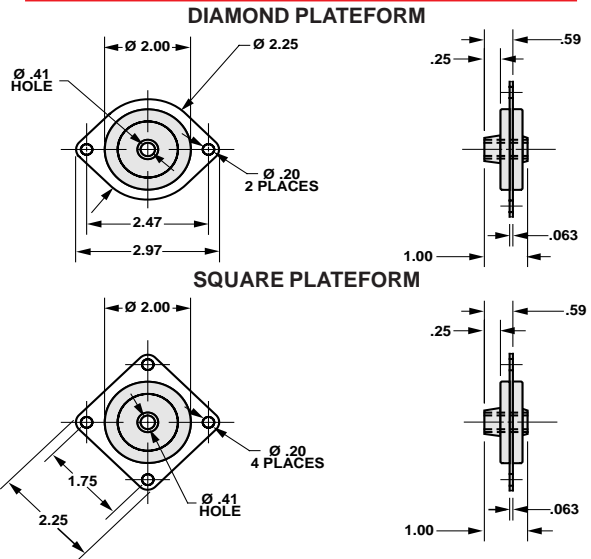

Hardware Options

NUMBER OF WASHERS	HARDWARE CODE	
	SQUARE PLATFORM	DIAMOND PLATFORM
0	10	20
1	11	21
2	12	22

WASHER DIMENSIONS		
INSIDE DIAMETER (in)	OUTSIDE DIAMETER (in)	THICKNESS (in)
.39	1.88	.06

LOAD VS. SYSTEM NATURAL FREQUENCY

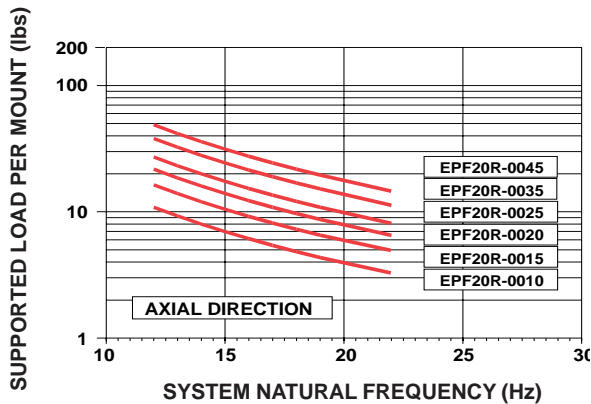

LOAD VS. DEFLECTION

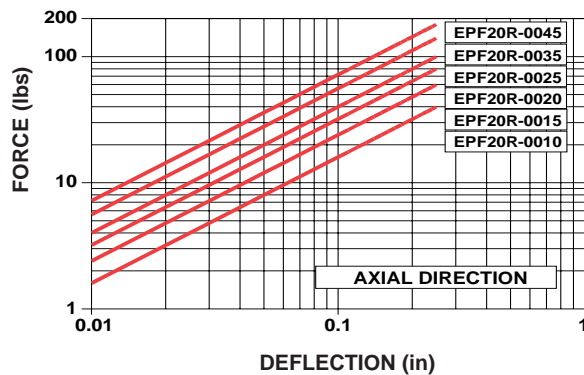

EPF20R Platform Series

Metric
Data

Load Range: 15 to 200 N

all dimensions in
millimeters

Features & Benefits

- Easy to Install
- Provides Uniform Stress Distribution
- Loading in the Axial Direction
- Minimum Installation Space Required

Material Information

- Elastomer: Natural Rubber
- Metals: Low Carbon Steel
Rust Preventative Coating
- Temperature Range: -40°C to 80°C

Typical Applications

- Air Conditioners
- Appliances
- Business Machines
- Electronics
- Small Generators

Mount Installation

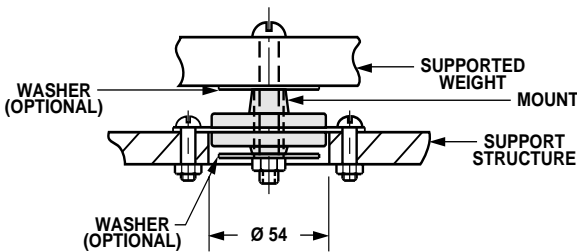

LOAD VS. SYSTEM NATURAL FREQUENCY

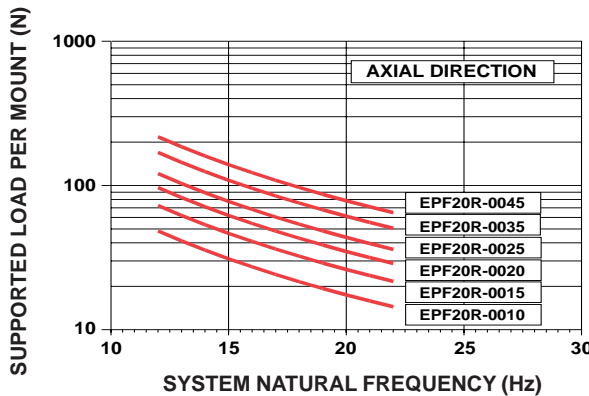

Mount Dimensions

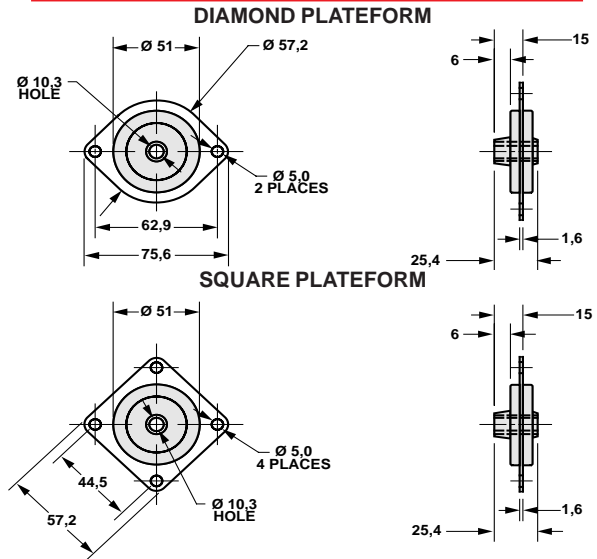

Hardware Options

NUMBER OF WASHERS	HARDWARE CODE	
	SQUARE PLATFORM	DIAMOND PLATFORM
0	10	20
1	11	21
2	12	22

WASHER DIMENSIONS		
INSIDE DIAMETER (mm)	OUTSIDE DIAMETER (mm)	THICKNESS (mm)
9,9	47,6	1,5

LOAD VS. DEFLECTION

