

# ELP43N Low Profile Mount Series

Imperial  
Data

Axial Load Range: 60 to 100 lbs  
Radial Load Range: 60 to 100 lbs

all dimensions in  
inches

## Features & Benefits

- Rugged Construction
- Low Natural Frequency
- Loading in the Axial or Radial Direction
- Radial to Axial Stiffness Ratio is Approximately 1:1

## Material Information

- Elastomer: Neoprene
- Metals: Low Carbon Steel  
Rust Preventative Coating
- Temperature Range: 0°F to 200°F

## Typical Applications

- Air Conditioning Units
- Compressors
- Electronic Equipment
- Engines
- Shipboard Equipment

## Mount Installation

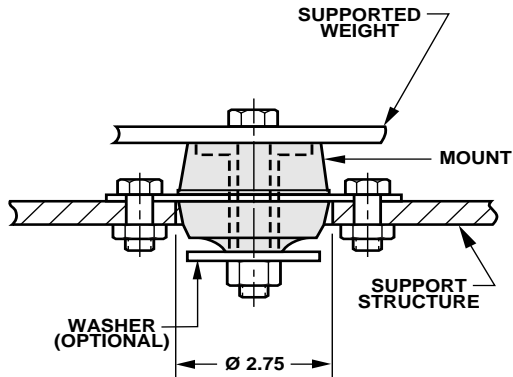

## LOAD VS. SYSTEM NATURAL FREQUENCY

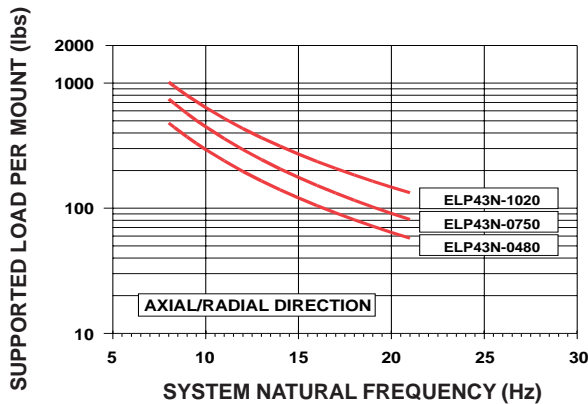

## Mount Dimensions

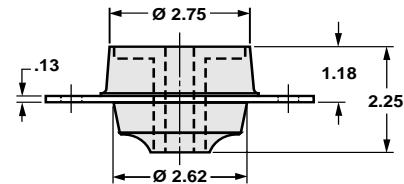
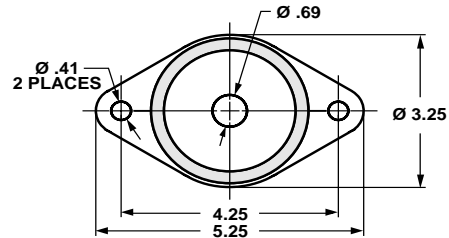

## Hardware Options

NUMBER OF WASHERS	HARDWARE CODE
0	00
1	01

WASHER DIMENSIONS		
INSIDE DIAMETER (in)	OUTSIDE DIAMETER (in)	THICKNESS (in)
.64	2.25	.15

## LOAD VS. DEFLECTION

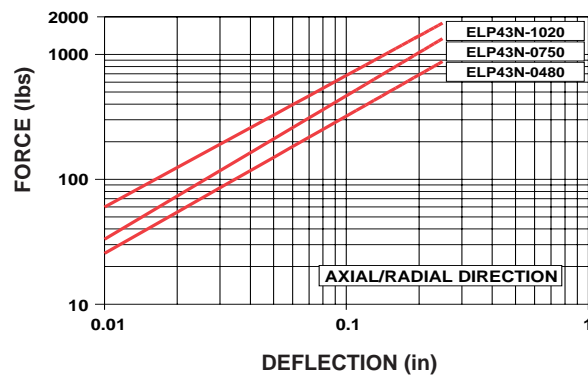

# ELP43N Low Profile Mount Series

Axial Load Range: 250 to 4500 N

Radial Load Range: 250 to 4500 N

Metric  
Data

all dimensions in  
millimeters

## Features & Benefits

- Rugged Construction
- Low Natural Frequency
- Loading in the Axial or Radial Direction
- Radial to Axial Stiffness Ratio is Approximately 1:1

## Material Information

- Elastomer: Neoprene
- Metals: Low Carbon Steel  
Rust Preventative Coating
- Temperature Range: -20°C to 90°C

## Typical Applications

- Air Conditioning Units
- Compressors
- Electronic Equipment
- Engines
- Shipboard Equipment

## Mount Installation

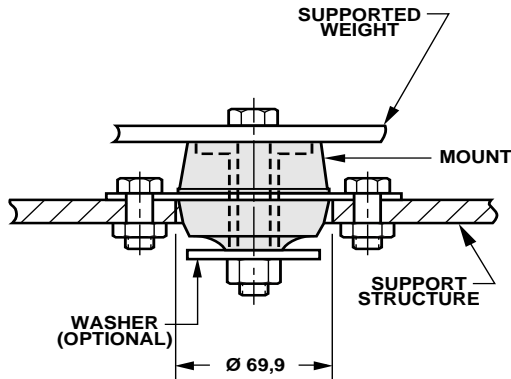

## LOAD VS. SYSTEM NATURAL FREQUENCY

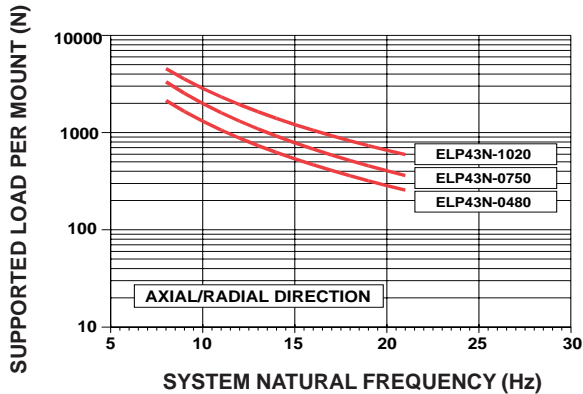

## Mount Dimensions

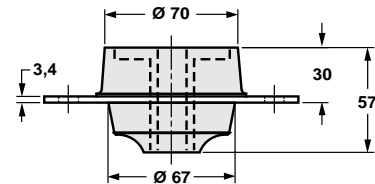
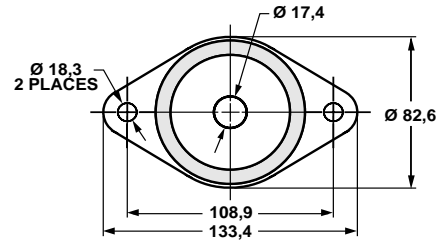

## Hardware Options

NUMBER OF WASHERS	HARDWARE CODE
0	00
1	01

WASHER DIMENSIONS		
INSIDE DIAMETER (mm)	OUTSIDE DIAMETER (mm)	THICKNESS (mm)
16	57	4

## LOAD VS. DEFLECTION

